

US 220/88° V10	
V	mm 10
altezza height	mm 80
angolo degree	88°
raggio radius	mm 0,8
stelo stem	mm 18
acciaio steel	C45T HRC 52+58
temprato induzione - induction hardened	
carico load MAX	1000 kN/mt
lunghezze lengths	peso weight
mm 835	kg 16,8
mm 415	kg 7,1
mm 805 fraz	kg 13,7
10+15+20+40+50+100+100+200+370	

US 420/88° V10	
V	mm 10
altezza height	mm 120
angolo degree	88°
raggio radius	mm 0,8
stelo stem	mm 18
acciaio steel	C45T HRC 52+58
temprato induzione - induction hardened	
carico load MAX	1000 kN/mt
lunghezze lengths	peso weight
mm 835	kg 19,1
mm 415	kg 9,6
mm 805 fraz	kg 18,4
10+15+20+40+50+100+100+200+370	

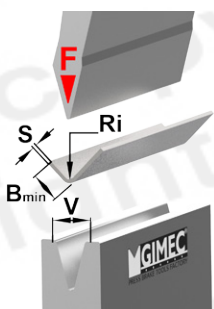

PIEGATURA IN ARIA - AIR BENDING			
V		mm 10	
S	spessore - thickness mm	1,2	1,5
F	kN/mt	R 200 N/mm <sup>2</sup>	40
		R 450 N/mm <sup>2</sup>	100
		R 700 N/mm <sup>2</sup>	150
Ri	raggio int. - int.radius	1,7	
B	90° B min mm	7,1	

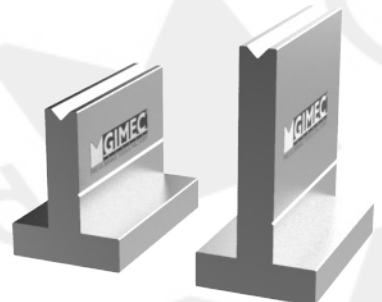

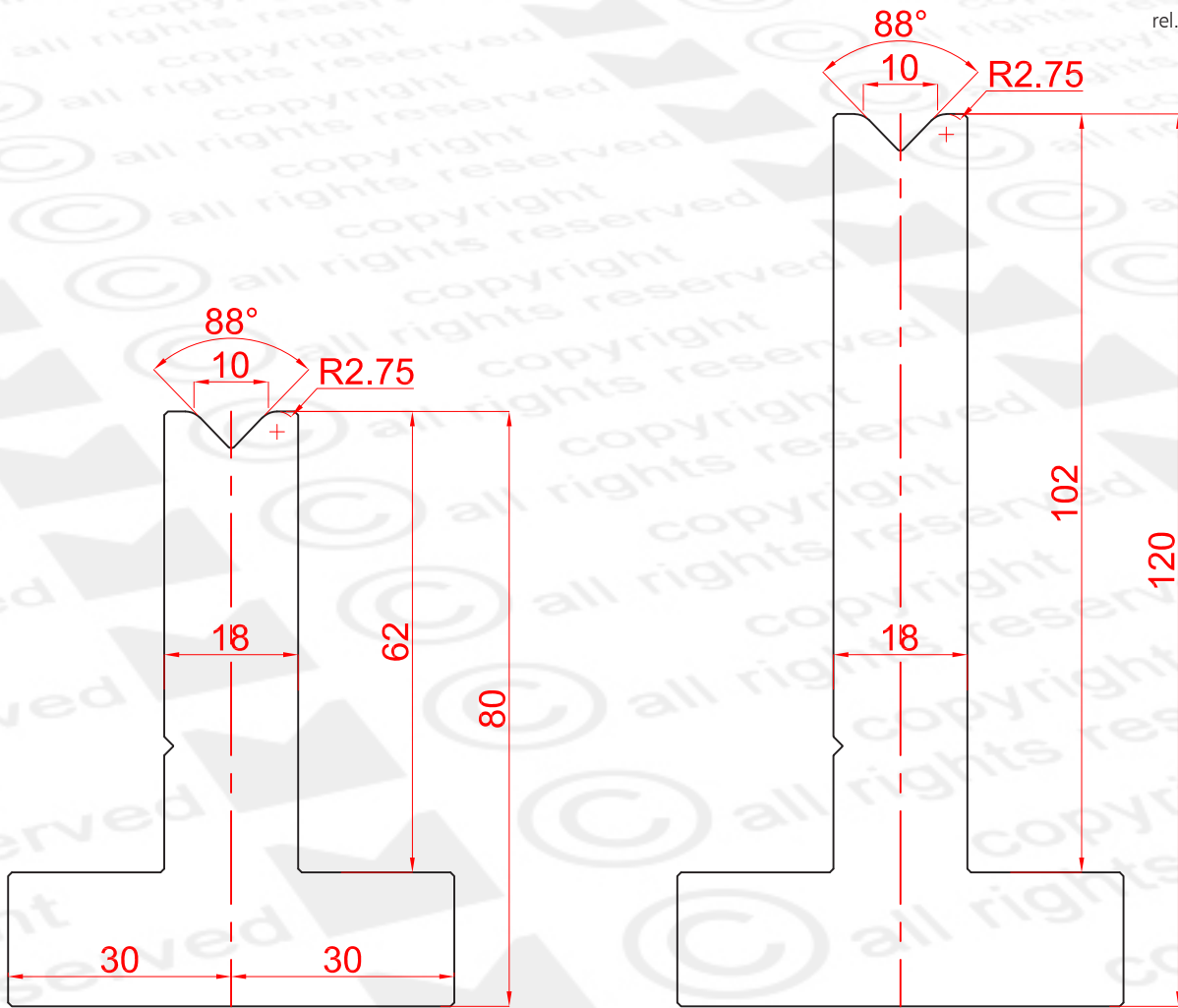

US 220/88° V10 R	
V	mm 10
altezza height	mm 80
angolo degree	88°
raggio radius	mm 2,75
stelo stem	mm 18
acciaio steel	C45T HRC 52+58
temprato induzione - induction hardened	
carico load MAX	1000 kN/mt
lunghezze lengths	peso weight
mm 835	kg 16,8
mm 415	kg 7,1
mm 805 fraz	kg 13,7
10+15+20+40+50+100+100+200+370	

US 420/88° V10 R	
V	mm 10
altezza height	mm 120
angolo degree	88°
raggio radius	mm 2,75
stelo stem	mm 18
acciaio steel	C45T HRC 52+58
temprato induzione - induction hardened	
carico load MAX	1000 kN/mt
lunghezze lengths	peso weight
mm 835	kg 19,1
mm 415	kg 9,6
mm 805 fraz	kg 18,4
10+15+20+40+50+100+100+200+370	

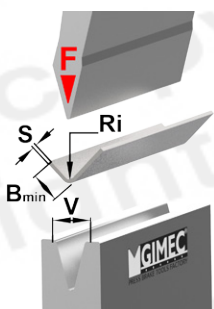

PIEGATURA IN ARIA - AIR BENDING			
V		mm 10	
S	spessore - thickness mm	1,2	1,5
F	kN/mt	R 200 N/mm <sup>2</sup>	40
		R 450 N/mm <sup>2</sup>	100
		R 700 N/mm <sup>2</sup>	150
Ri	raggio int. - int.radius	1,7	
B	90° B min mm	7,1	

