

US 220/60° V6	
V	mm 6
altezza height	mm 80
angolo degree	60°
raggio radius	mm 0,5
stelo stem	mm 14
acciaio steel	C45T HRC 52+58
temprato induzione - induction hardened	
carico load MAX	800 kN/mt
lunghezze lengths	peso weight
mm 835	kg 12,7
mm 415	kg 6,3
mm 805 fraz	kg 12,2
10+15+20+40+50+100+100+200+370	

US 420/60° V6	
V	mm 6
altezza height	mm 120
angolo degree	60°
raggio radius	mm 0,5
stelo stem	mm 14
acciaio steel	C45T HRC 52+58
temprato induzione - induction hardened	
carico load MAX	800 kN/mt
lunghezze lengths	peso weight
mm 835	kg 16,5
mm 415	kg 8,2
mm 805 fraz	kg 15,9
10+15+20+40+50+100+100+200+370	

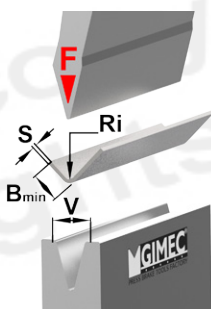

PIEGATURA IN ARIA - AIR BENDING				
V		mm 6		
S	spessore - thickness mm	0,6	0,8	1,0
F	R 200 N/mm <sup>2</sup>	20	30	60
	R 450 N/mm <sup>2</sup>	40	70	130
	R 700 N/mm <sup>2</sup>	80	110	190
Ri	raggio int. - int.radius	1,0		
B	90° B min mm	4,3		



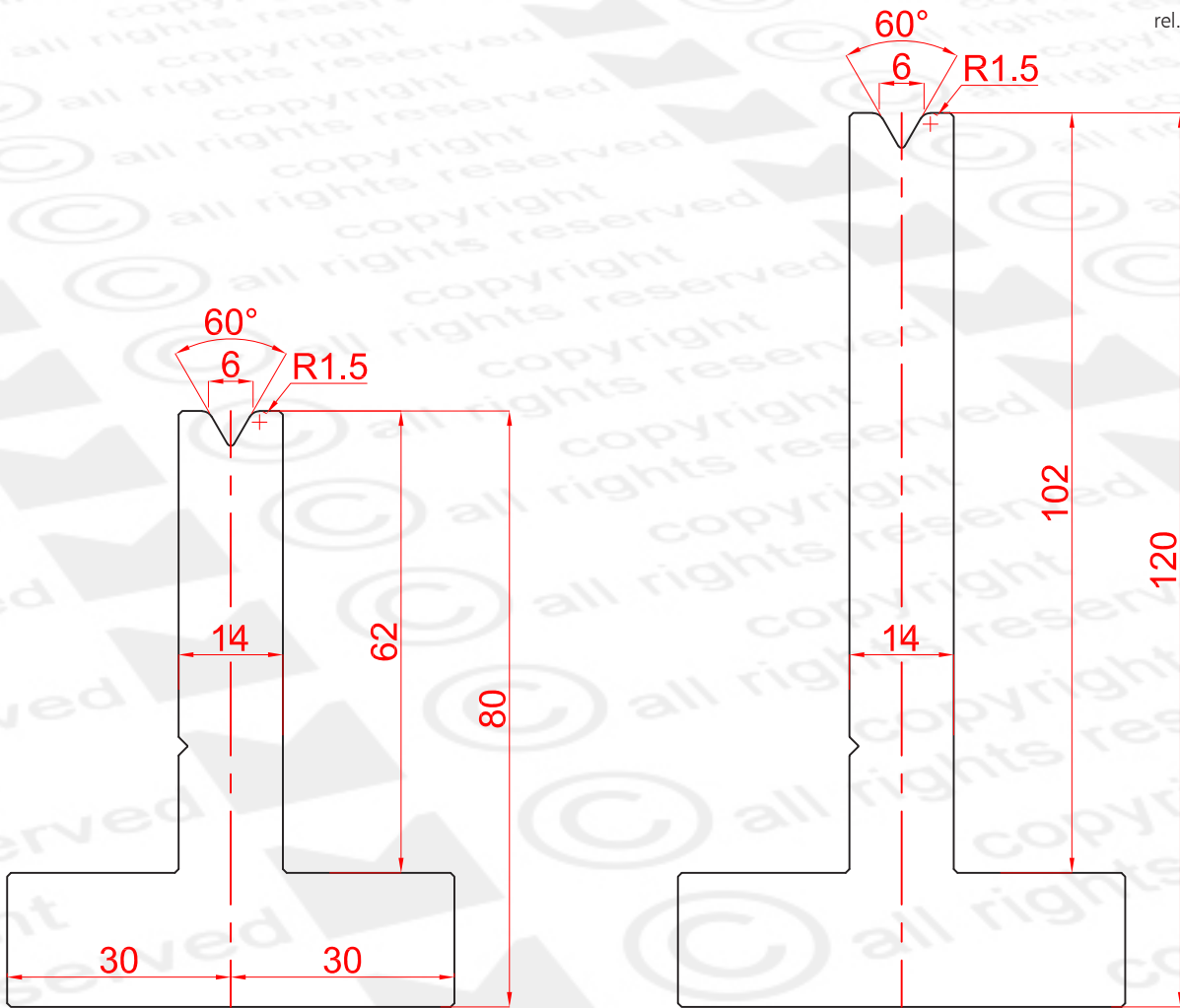

US 220/60° V6 R	
V	mm 6
altezza height	mm 80
angolo degree	60°
raggio radius	mm 1,5
stelo stem	mm 14
acciaio steel	C45T HRC 52+58
temprato induzione - induction hardened	
carico load MAX	800 kN/mt
lunghezze lengths	peso weight
mm 835	kg 12,7
mm 415	kg 6,3
mm 805 fraz	kg 12,2
10+15+20+40+50+100+100+200+370	

US 420/60° V6 R	
V	mm 6
altezza height	mm 120
angolo degree	60°
raggio radius	mm 1,5
stelo stem	mm 14
acciaio steel	C45T HRC 52+58
temprato induzione - induction hardened	
carico load MAX	800 kN/mt
lunghezze lengths	peso weight
mm 835	kg 16,5
mm 415	kg 8,2
mm 805 fraz	kg 15,9
10+15+20+40+50+100+100+200+370	

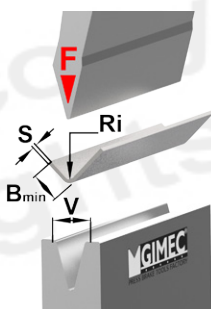

PIEGATURA IN ARIA - AIR BENDING				
V		mm 6		
S spessore - thickness mm		0,6	0,8	1,0
F kN/mt	R 200 N/mm <sup>2</sup>	20	30	60
	R 450 N/mm <sup>2</sup>	40	70	130
	R 700 N/mm <sup>2</sup>	80	110	190
Ri	raggio int. - int.radius	1,0		
B	90° B min mm	4,3		

