

altezza height mm	67,0
angolo degree	60°
raggio radius	0,8
acciaio steel	C45 T HRC 52÷58
temprato induzione - induction hardened	
carico load MAX	800 kN/mt

lunghezze lengths	peso weight
mm 835	kg 8,7
mm 415	kg 4,3
mm 805 fraz	kg 8,4
10+15+20+40+50+100+100S+100D+370	

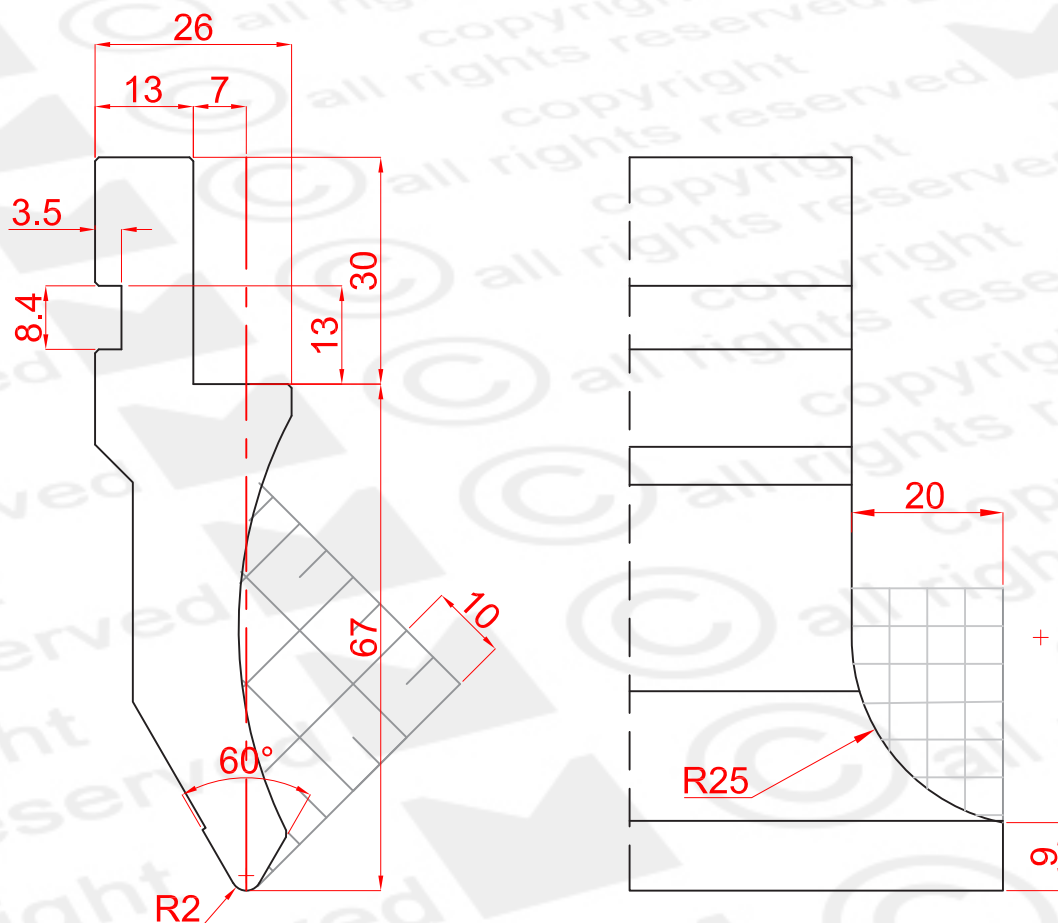



altezza height mm	67,0
angolo degree	60°
raggio radius	2,0
acciaio steel	C45 T HRC 52+58
temprato induzione - induction hardened	
carico load MAX	800 kN/mt

lunghezze lengths	peso weight
mm 835	kg 8,8
mm 415	kg 4,4
mm 805 fraz	kg 8,5
10+15+20+40+50+100+100S+100D+370	

