

altezza height mm	117,0
angolo degree	26°
raggio radius	0,8
acciaio steel	C45 T HRC 52÷58
temprato induzione - induction hardened	
carico load MAX	1000 kN/mt

lunghezze lengths	peso weight
mm 835	kg 13,5
mm 415	kg 6,7
mm 805 fraz	kg 13,0
10+15+20+40+50+100+100S+100D+370	

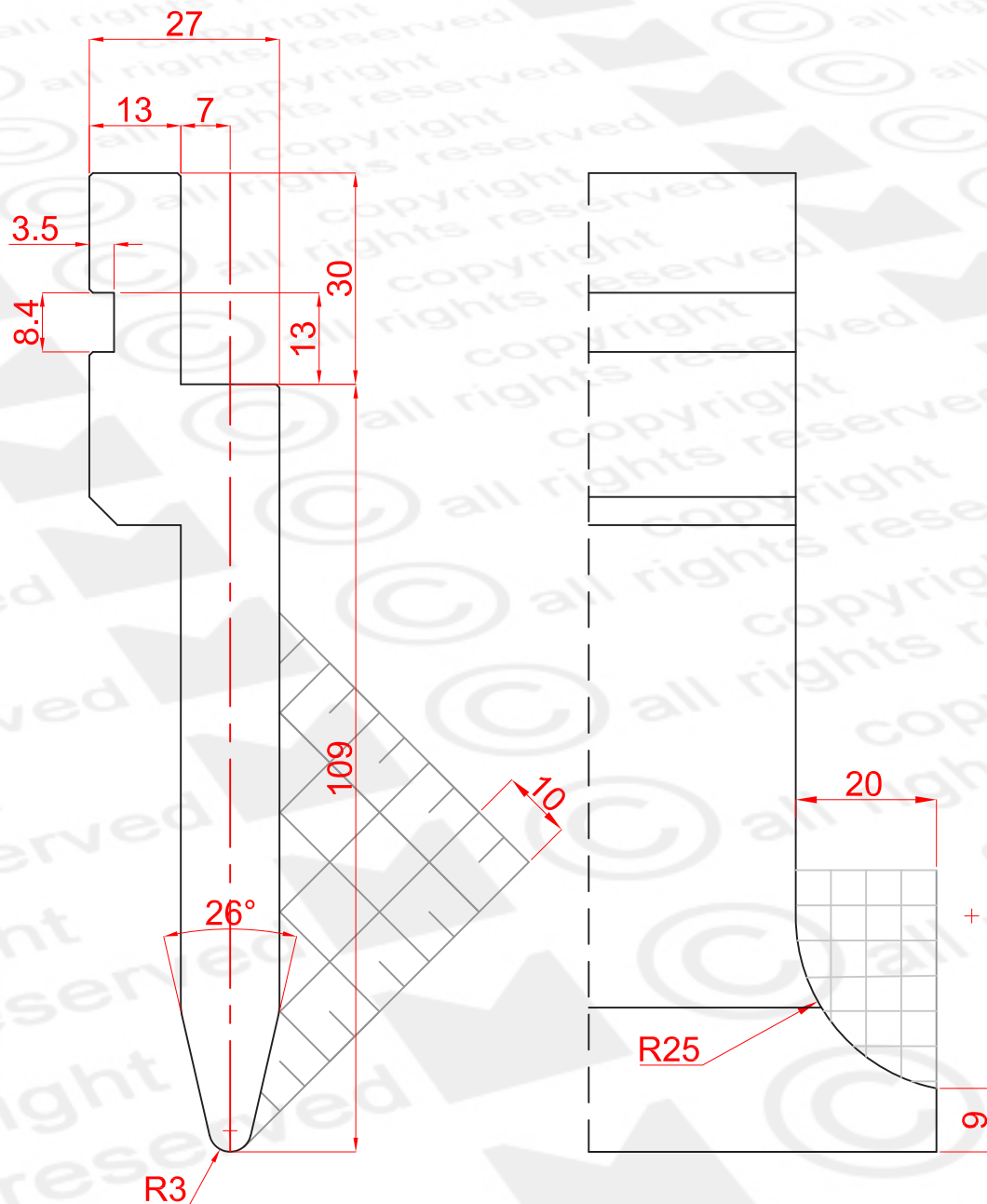



altezza height mm	109,0
angolo degree	26°
raggio radius	3,0
acciaio steel	C45 T HRC 52÷58
temprato induzione - induction hardened	
carico load MAX	1000 kN/mt

lunghezze lengths	peso weight
mm 835	kg 13,0
mm 415	kg 6,4
mm 805 fraz	kg 12,5
10+15+20+40+50+100+100S+100D+370	

