

altezza height mm	86,0
angolo degree	35°
raggio radius	0,8
acciaio steel	C45 T HRC 52÷58
temprato induzione - induction hardened	
carico load MAX	700 kN/mt

lunghezze lengths	peso weight
mm 835	kg 11,1
mm 415	kg 5,5
mm 805 fraz	kg 10,7
10+15+20+40+50+100+100S+100D+370	

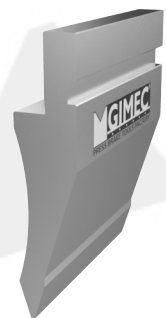

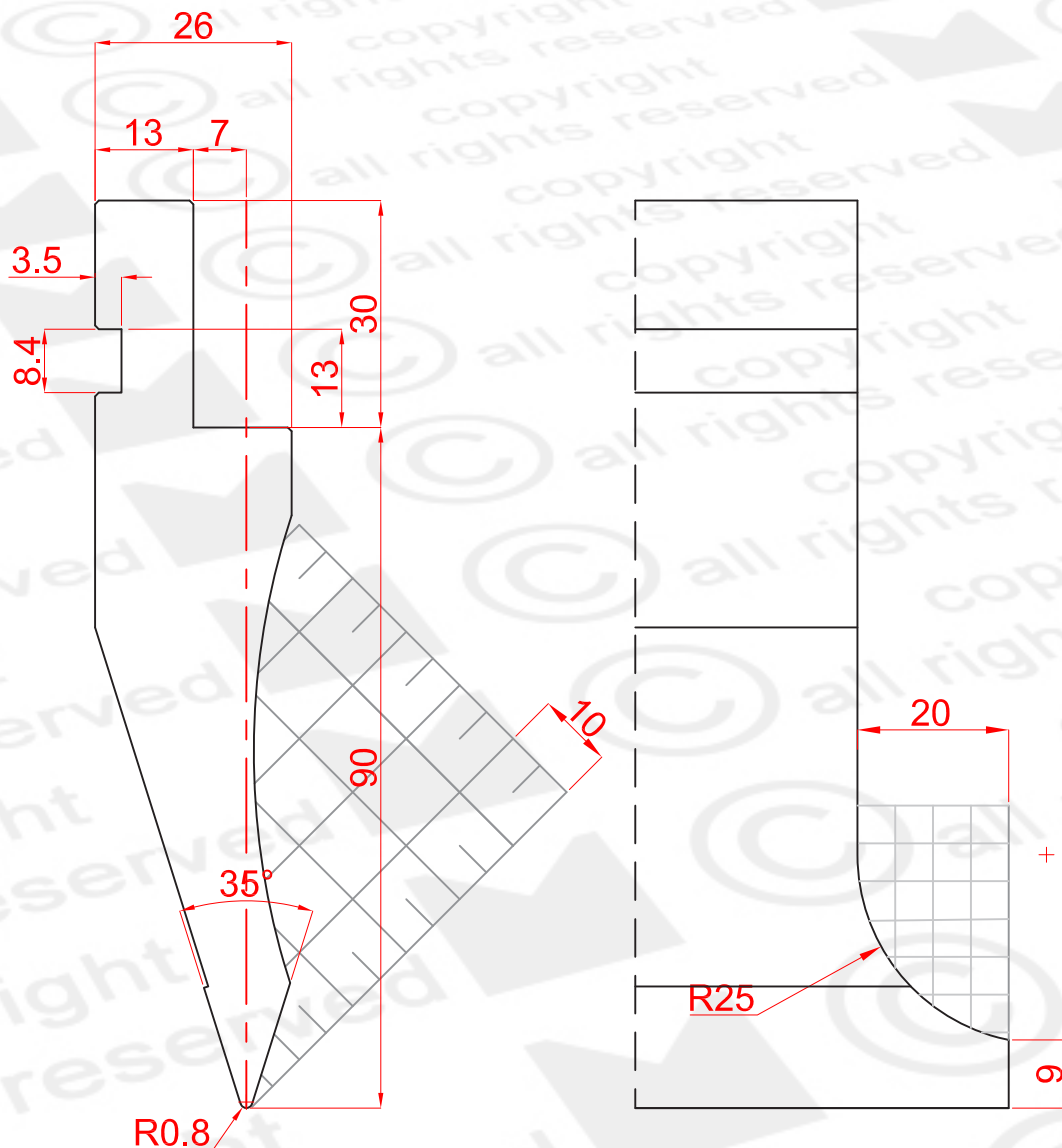

altezza height mm	90,0
angolo degree	35°
raggio radius	0,8
acciaio steel	C45 T HRC 52+58
temprato induzione - induction hardened	
carico load MAX	700 kN/mt

lunghezze lengths	peso weight
mm 835	kg 11,8
mm 415	kg 5,9
mm 805 fraz	kg 11,4
10+15+20+40+50+100+100S+100D+370	

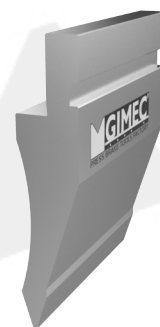

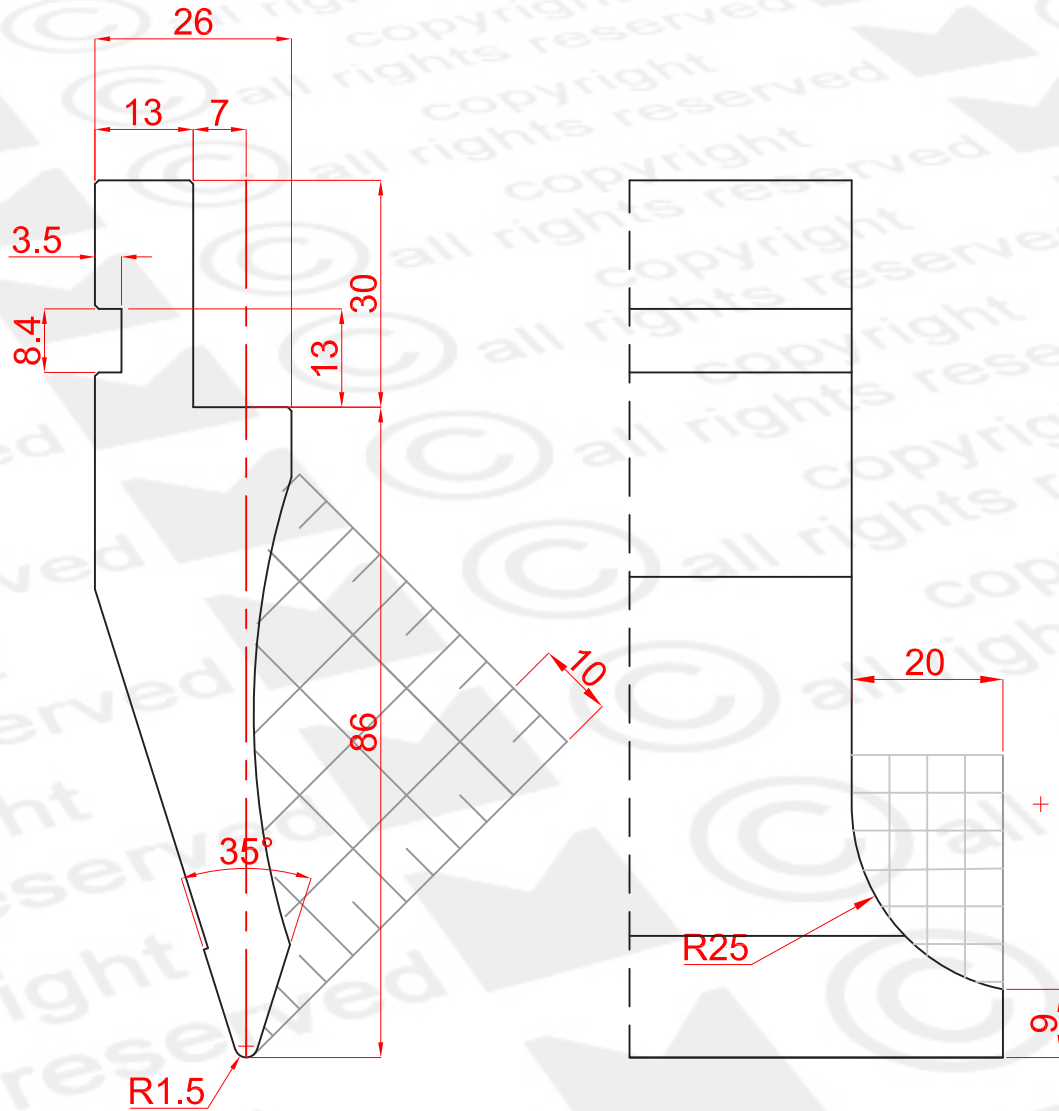

altezza height mm	86,0
angolo degree	35°
raggio radius	1,5
acciaio steel	C45 T HRC 52+58
temprato induzione - induction hardened	
carico load MAX	700 kN/mt

lunghezze lengths	peso weight
mm 835	kg 11,4
mm 415	kg 5,7
mm 805 fraz	kg 11,0
10+15+20+40+50+100+100S+100D+370	

