

altezza height mm	65,1
angolo degree	45°
raggio radius	0,8
acciaio steel	C45 T HRC 52+58
temprato induzione - induction hardened	
carico load MAX	800 kN/mt
lunghezze lengths	peso weight
mm 835	kg 9,2
mm 415	kg 4,6
mm 805 fraz	kg 8,9
10+15+20+40+50+100+100S+100D+370	

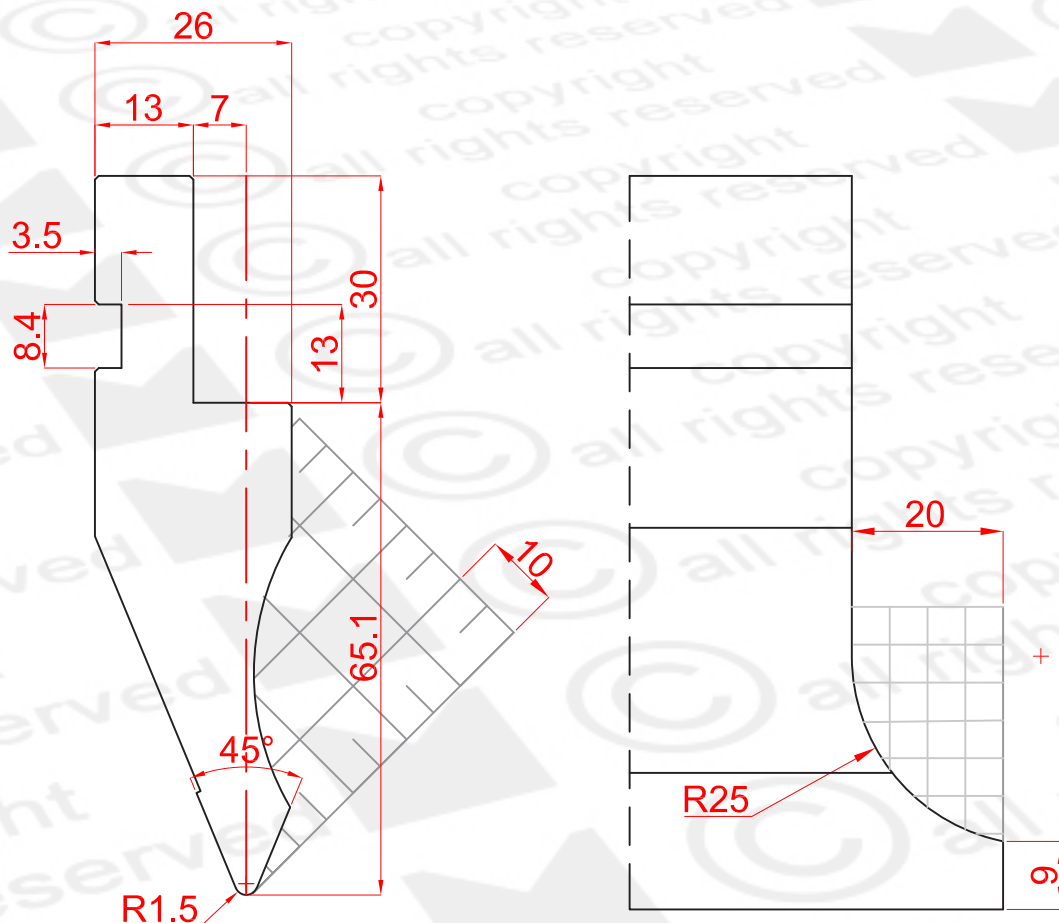



altezza height mm	65,1
angolo degree	45°
raggio radius	1,5
acciaio steel	C45 T HRC 52+58
temprato induzione - induction hardened	
carico load MAX	800 kN/mt

lunghezze lengths	peso weight
mm 835	kg 9,4
mm 415	kg 4,7
mm 805 fraz	kg 9,1
10+15+20+40+50+100+100S+100D+370	

